

szie: 210x297mm

SAWHORSE



▲ SAFETY INFORMATION

FOR YOUR SAFETY, PLEASE ENSURE YOU READ THESE INSTRUCTIONS CAREFULLY BEFORE USE, AND KEEP THESE INSTRUCTIONS IN THE WORK SPACE WHERE THE SAWHORSE WILL BE USED AT ALL TIMES.

SAFE OPERATION AND USE OF THIS SAWHORSE

- 1 When lifting the sawhorse use proper lifting techniques to avoid personal injury.
- 2 Ensure work area is well lighted while working.
- 3 Ensure saw horse is standing on a level surface that is clear, dry and free of debris.
- 4 Ensure all 4 legs have solid contact with the floor. If the saw horse is not positioned level and straight, loads placed upon it could fall, potentially causing damage to the item(s) loaded on it, and possible severe personal injury or death.
- 5 Ensure the load placed on any sawhorse does not exceed the applicable Safe Working Load Rating. Overloading can lead to failure of the sawhorse, potentially causing damage to the item(s) loaded on it, and possible severe personal injury or death.
- 6 Never stack sawhorses to obtain extra height.

Caution:
Do not apply weight in excess of 1,300 lbs (590 kg) of uniformly distributed load on Sawhorse. Do not use as a step ladder or standing platform.

Uniformly-Distributed Load
The maximum uniformly distributed load across the top rail of the saw horse, PER EACH SAW HORSE:
This means that the maximum weight that can be applied to this saw horse, per lineal foot, as is stated on the Retail Sticker and the instructions. "Uniformly-Distributed Load" means when all the weight is distributed evenly on the top rail. The amount of weight that can be applied to 2 identical saw horses is double this value. For example, a pallet or skid weighing not more than two times the Safe Working Load Rating can safely be carried by 2 of these saw horses.

WARNING! TO REDUCE THE RISK OF PERSONAL INJURY, USER MUST READ AND UNDERSTAND OPERATOR'S MANUAL. LEGS MUST BE LOCKED OPEN. DO NOT STAND ON SAWHORSE. DO NOT OVERLOAD. MAXIMUM CAPACITY 590KGS. USE ONLY ON A FLAT, DRY, HARD AND LEVEL SURFACE.

SET-UP INSTRUCTIONS/INSTRUCTIONS POUR LE MONTAGE/ INSTRUCCIONES DE ENSAMBLAJE

1. Sawhorse in folded/carry position.

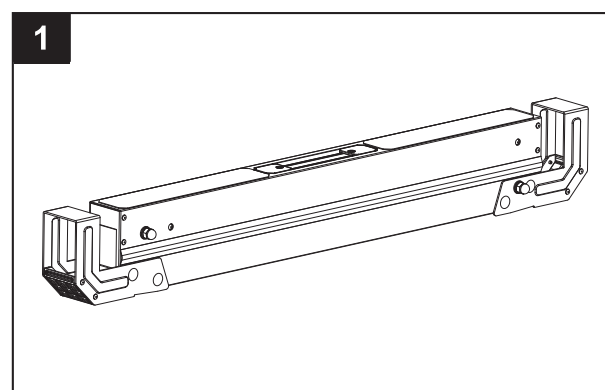

2. Press release button and pull down legs until 45x90mm supports are fully deployed.

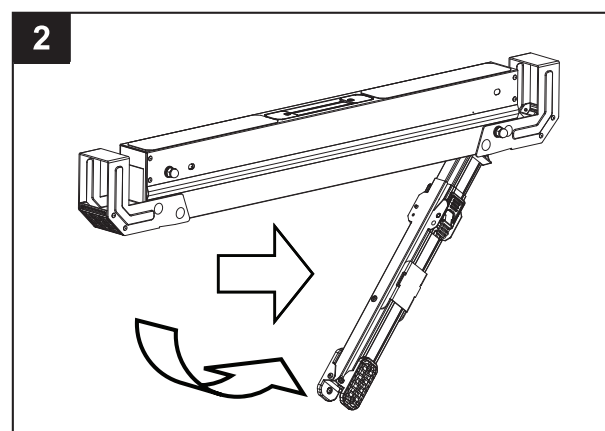

3. Separate legs and push cross brace flat.

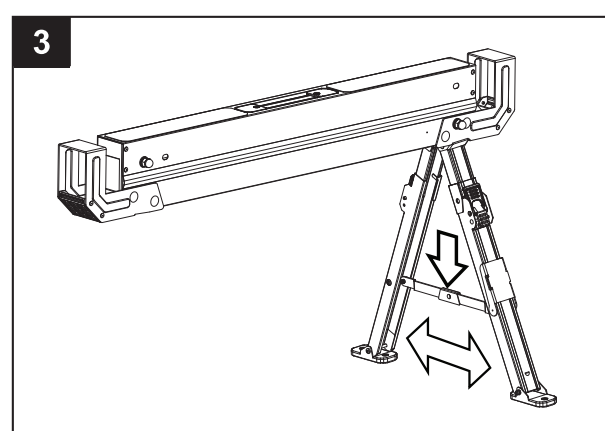

4. Press release button and fold down legs until 45x90mm supports are fully deployed.

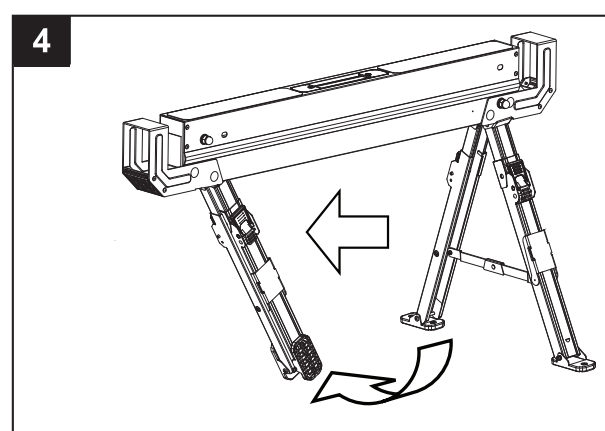

SET-UP INSTRUCTIONS/INSTRUCTIONS POUR LE MONTAGE/ INSTRUCCIONES DE ENSAMBLAJE

5. Separate legs and push cross brace flat.

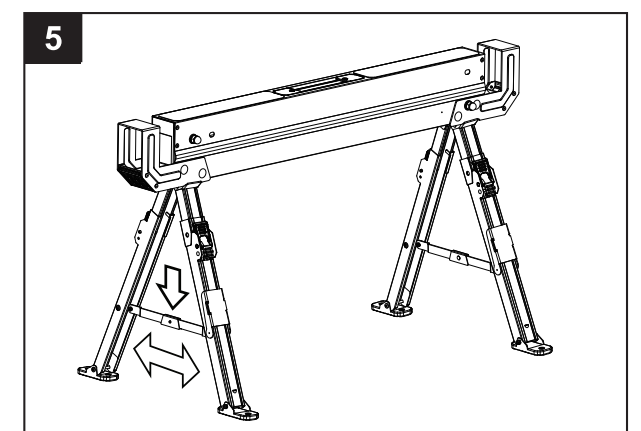

6. Legs adjust in increments of 1 inch. To extend, pull legs down until latch is locked at desired position. To retract, press lock button, pull legs down slightly then push leg up.

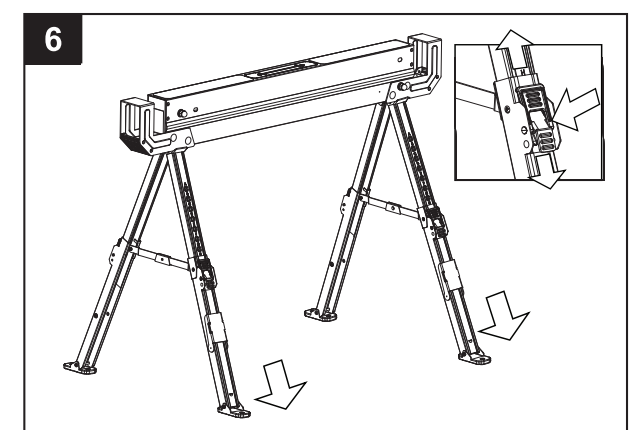

7. When paired together with a second unit and properly joined by 45x90mm in the support arms, a work table can support up to 1180 kgs.

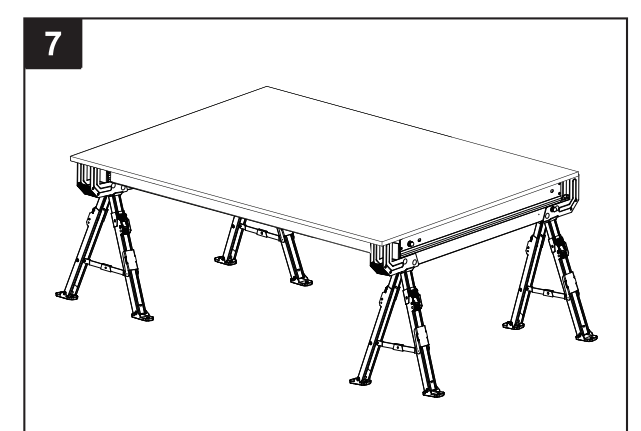

HOW TO CLOSE

1. To close, reverse steps 5 through 2, starting with leg 2.
2. Be sure locking pin engages main housing to keep legs secure while in folded/carry position.